

# 'T-8012' Series

## Heat Exchanger and Boiler Tube Expander

- More durable components
- Extended service life
- In built thrust bearing
- Heavy duty application

Tristar offers solutions to overcome any installation problem.

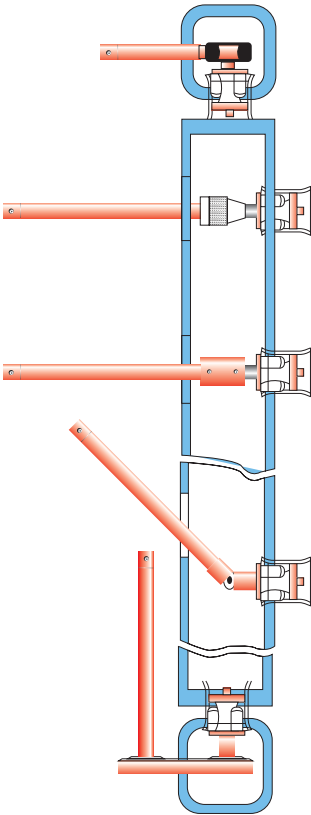

The various drive accessories developed are designed for optimum productivity and operator ease

T-8012 expanders can be supplied with 4 and 5 rollers

Tube O.D. inch	Bwg	Tube I.D.		Min I.D.		Max Expansion		Expander with 2.1/4" (57.15 mm) long rollers		
		inch	mm	inch	mm	inch	mm	Model No.	Mandrel	Rollers Set.
1.3/4 (44.45)	8	1.420	36.1	1.368	34.7	1.550	39.3	T 8012-1.3/4-8	TM-90	TR33-A
	10	1.482	37.6	1.420	36.0	1.607	40.8	T 8012-1.3/4-10		TR37-A
	11	1.510	38.3	1.454	36.9	1.635	41.5	T 8012-1.3/4-11		TR-42
	12	1.532	38.9	1.482	37.6	1.657	42.0	T 8012-1.3/4-12		TR-44
	13	1.560	39.6	1.510	38.3	1.685	42.7	T 8012-1.3/4-13		TR-46
	14	1.584	40.2	1.532	38.9	1.709	43.4	T 8012-1.3/4-14		TR-48
2 (50.8)	8	1.670	42.4	1.595	40.5	1.795	45.6	T 8012-2-8	TM-91	TR-48
	10	1.732	43.9	1.640	41.6	1.857	47.1	T 8012-2-10		TR-50
	11	1.760	44.7	1.670	42.4	1.885	47.8	T 8012-2-11		TR-52
	12	1.782	45.2	1.704	43.4	1.970	48.4	T 8012-2-12		TR-54
	13	1.810	45.9	1.732	43.9	1.956	49.6	T 8012-2-13-18		TR-56
	14	1.834	46.5	1.732	43.9	1.956	49.6	T 8012-2-13-18		TR-56
	15	1.856	47.1	1.732	43.9	1.956	49.6	T 8012-2-13-18		TR-56
	16	1.870	47.4	1.732	43.9	1.956	49.6	T 8012-2-13-18		TR-56
	17	1.884	47.9	1.732	43.9	1.956	49.6	T 8012-2-13-18		TR-56
	18	1.902	48.3	1.732	43.9	1.956	49.6	T 8012-2-13-18		TR-56
2.1/4	10	1.982	50.3	1.890	48.0	2.107	53.5	T8012-2.1/4-10	TM-92	TR-56
	11	2.010	51.0	1.920	48.7	2.137	54.2	T8012-2.1/4-11		TR-58
	12	2.032	51.6	1.954	49.6	2.157	54.7	T8012-2.1/4-12		TR-60
	13	2.060	52.3	1.982	50.3	2.185	55.4	T8012-2.1/4-13-16		TR-62
	14	2.084	52.9	1.982	50.3	2.185	55.4	T8012-2.1/4-13-16		TR-62
	15	2.106	53.4	1.982	50.3	2.185	55.4	T8012-2.1/4-13-16		TR-62
	16	2.120	53.8	1.982	50.3	2.185	55.4	T8012-2.1/4-13-16		TR-62
2.1/2"	10	2.232	56.6	2.140	54.3	2.407	61.1	T8012-2.1/2-10-12	TM-93	TR-64
	11	2.260	57.4	2.140	54.3	2.407	61.1	T8012-2.1/2-10-12		TR-64

T8012 Series	Adjustable Range	
	Roller Length	Min. Max.
2.1/4" (57.1 mm)	1/2" (12.7 mm)	4" (101.6 mm)

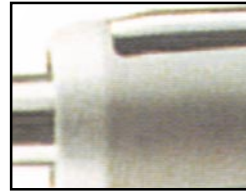

Tube O.D. inch	Thk bwg	Tube I.D.		Min I.D.		Max Expansion		Expander with 2.1/4" (57.15 mm) long rollers		
		inch	mm	inch	mm	inch	mm	Model No.	Mandrel	Rollers Set.
12	2.282	57.9	2.140	54.3	2.407	61.1	80.1	T8012-2.1/2-10-12	TM-94	TR-64
	13	2.310	58.6	2.232	56.6	2.450	62.2	T8012-2.1/2-13-18		TR-64
	14	2.334	59.2	2.232	56.6	2.450	62.2	T8012-2.1/2-13-18		TR-64
	15	2.356	59.8	2.232	56.6	2.450	62.2	T8012-2.1/2-13-18		TR-64
	16	2.370	60.1	2.232	56.6	2.450	62.2	T8012-2.1/2-13-18		TR-64
	17	2.384	60.6	2.232	56.6	2.450	62.2	T8012-2.1/2-13-18		TR-64
	18	2.402	61.0	2.232	56.6	2.450	62.2	T8012-2.1/2-13-18		TR-64
2.3/4	10	2.482	63.0	2.390	60.7	2.702	68.6	T8012-2.3/4-10-16	TM-96	TR-66
	11	2.510	63.7	2.390	60.7	2.702	68.6	T8012-2.3/4-10-16		TR-66
	12	2.532	64.3	2.390	60.7	2.702	68.6	T8012-2.3/4-10-16		TR-66
	13	2.560	65.0	2.390	60.7	2.702	68.6	T8012-2.3/4-10-16		TR-66
	14	2.584	65.6	2.390	60.7	2.702	68.6	T8012-2.3/4-10-16		TR-66
	15	2.606	66.1	2.390	60.7	2.702	68.6	T8012-2.3/4-10-16		TR-66
	16	2.620	66.6	2.390	60.7	2.702	68.6	T8012-2.3/4-10-16		TR-66
3	8	2.670	67.8	2.560	65.0	2.829	71.8	T8012-3-8-9	TM-97	TR-67
	9	2.701	68.6	2.560	65.0	2.829	71.8	T8012-3-8-9		TR-67
	10	2.732	69.3	2.640	67.0	2.952	74.9	T8012-3-10-18	TM-96	TR-67
	11	2.760	70.1	2.640	67.0	2.952	74.9	T8012-3-10-18		TR-67
	12	2.782	70.6	2.640	67.0	2.952	74.9	T8012-3-10-18		TR-67
	13	2.810	71.3	2.640	67.0	2.952	74.9	T8012-3-10-18		TR-67
	14	2.834	71.9	2.640	67.0	2.952	74.9	T8012-3-10-18		TR-67
	15	2.856	72.5	2.640	67.0	2.952	74.9	T8012-3-10-18		TR-67
	16	2.870	72.8	2.640	67.0	2.952	74.9	T8012-3-10-18		TR-67
17	2.884	73.3	2.640	67.0	2.952	74.9	T8012-3-10-18		TR-67	
18	2.902	73.7	2.640	67.0	2.952	74.9	T8012-3-10-18		TR-67	

